

INSTALLATION INSTRUCTIONS

FOR

HOYER

HBU-6 AND HSP-6 SURFACE MOUNTED SLEEVE

The layout required for installation of a surface mounted sleeve is shown in the diagram at the right. Proper position for the mast is 8" to 10" from the edge of the tub or pool. The base itself is 12" square. Position the edge of the base 2" to 4" from the edge of the pool with the edge of the base parallel to the edge of the pool. Mark the location of the four mounting bolt holes.

When the surface mounted sleeve is to be installed on a concrete surface, the four mounting holes must be drilled into the concrete to a depth of at least 2-3/4". Use a 1-1/8" core drill for best results. Set the four 5/8"x 4-1/2" bolts in the holes and fill around with a non-shrinking cement such as Por-Rok. Be sure the bolts are located in a 8-3/4" square and that they project at least 1-1/2" above the finished surface. When the concrete has cured, place the base in position over the bolts and secure with a washer and nut.

When the surface mounted sleeve is to be installed on a wood surface such as a boat dock, drill the four 5/8" mounting holes thru the planking. Reinforce the underside of the structure with heavy angle iron or similar material. The bolts holding the base must pass thru the planking and the angle iron below. In the event the bolts supplied are not long enough, it is suggested that longer 5/8" bolts be purchased locally. Be sure the base is solid before using lifter.

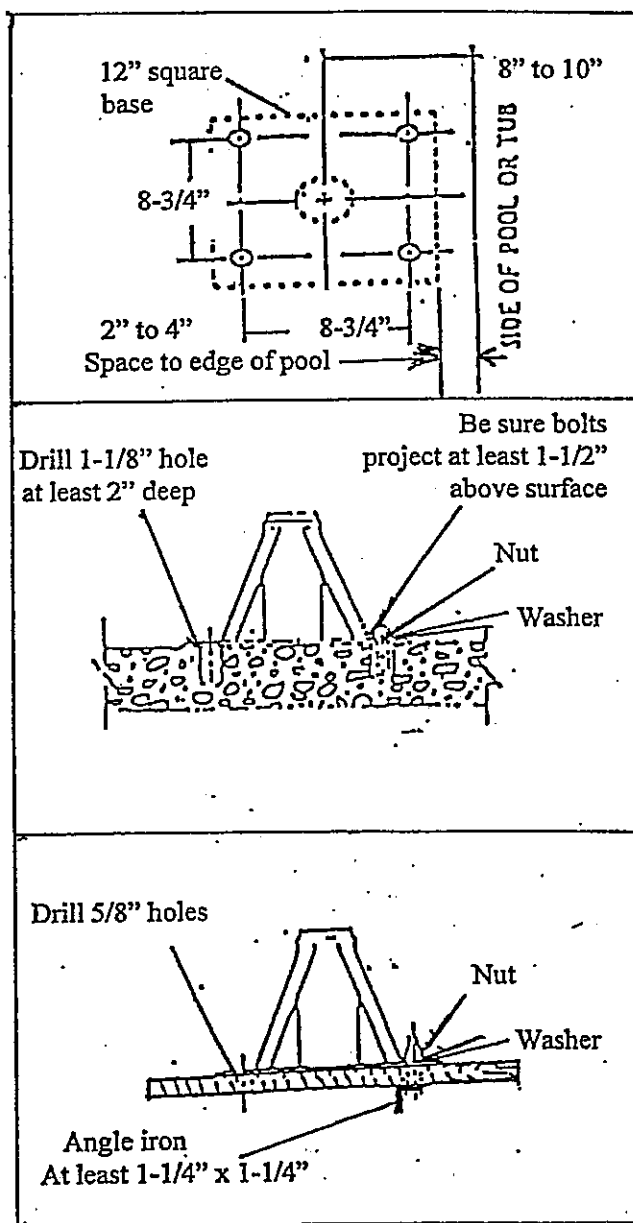

For SWIM POOL LIFTER (Cement-in Sleeve)

Notice: All sleeves are now being supplied for flush installation with flush cover.

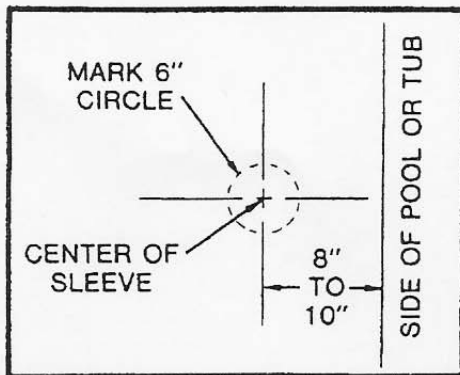

The layout required for the cement-in sleeve is shown on the diagram to the left. Proper position for the mast is 8 to 10 inches from the edge of the pool or tub. The cement-in sleeve itself is a cylinder 3¼-inches in diameter and 8-inches long. Mark a 6-inch circle if existing concrete is to be removed. In a new installation, position the sleeve on center and flush with grade.

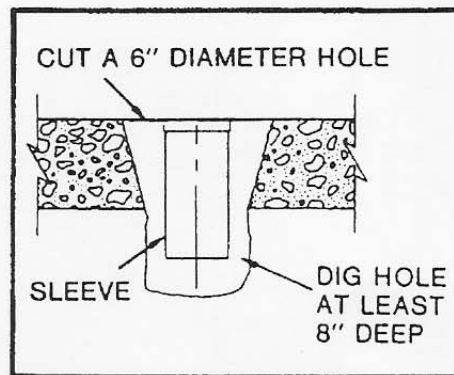

When the cement-in sleeve is to be installed in an existing concrete floor or deck, a hole at least 6-inches in diameter must be cut. The opening must be at least 8-inches deep. Fill the bottom of the hole with a non-shrinking cement, such as Por-Rok. Make sure the sleeve is perfectly vertical. Fill in around the sleeve with more non-shrinking cement. Allow the cement to set-up and finish the top surface.

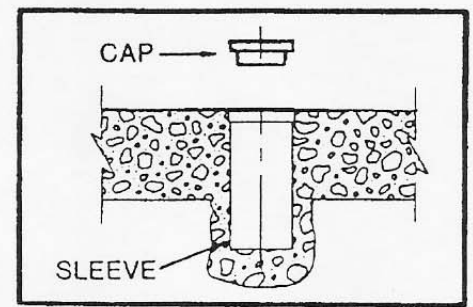

The diagram above shows a cross section of the finished installation for the cement-in sleeve. Notice that the sleeve is completely imbedded in cement and that a good bond is secured between the new and old concrete. When installing the sleeve in a new job, position the sleeve and line it up when the forms are being installed. Pour the concrete around the sleeve as the deck or floor is poured. No special type of concrete is required. (A wad of newspaper stuffed into the top of the sleeve will keep the interior free of concrete while the floor is being poured.)

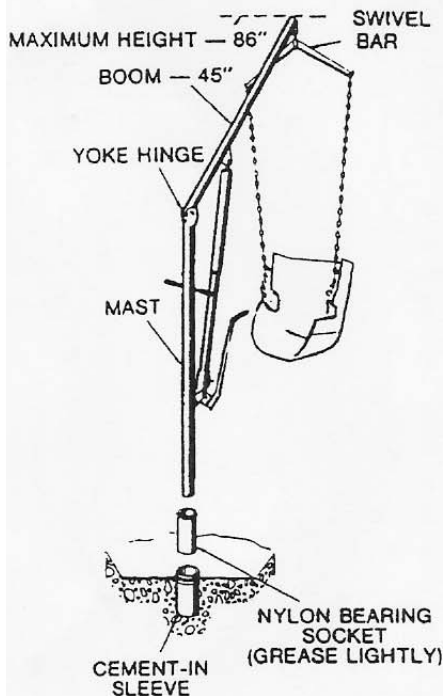

INSTALLATION OF LIFTER

When the sleeve has been installed (as described above) and the concrete has had several days to cure, the lifter may be installed. The nylon bearing socket supplied with the lifter must be installed in the sleeve. Grease the outside of the socket lightly before it is inserted into the sleeve. This will prevent corrosion which may cause the socket to stick in the sleeve. (It is suggested that the socket be removed occasionally also, to prevent corrosion.) Vaseline is an excellent lubricant if no commercial grease is on hand.

With the socket in place, unpack the lifter and insert the base of the mast into the socket and sleeve. To attach the end of the boom in the yoke hinge at the top of the mast, remove the wing nut and bolt from the yoke hinge and insert the boom end. Reinsert the bolt and secure with the wing nut. Attach the swivel bar to the boom end to keep the chains apart. The lifter is now ready for use.

A cover is supplied to prevent water from accumulating in the sleeve. This cover must be placed on the sleeve at all times when the mast is not in place.

MAINTENANCE

Put a drop of oil on the joints at the top of the mast, top and bottom of the pump, and the swivel bar hook every other month. While oiling the lifter, check all the cap nuts and bolts to be sure they are tight.

Put a drop of oil on the pump handle hinge when the Hoyer lifter is put into service and oil again every other month. This is very important as the holes in the hinge socket will wear when dry.

PLEASE NOTE: IN HIGH HUMIDITY OR SALT AREAS, WAX EXPOSED LIFTER PARTS PERIODICALLY TO HELP PREVENT CORROSION.

KEEP LIFTER DRY AND CLEAN

INSTRUCTIONS FOR OPERATION

To use the Hoyer Swimming Pool Lifter, remove the cover from the floor sleeve and insert the nylon bearing socket. Insert the mast of the lifter into the socket. Attach the long chains to the swivel bar. To use the #112-D, place the sling under the patient so that the end of the seat comes to his knees. Attach the ends of the chains to the swivel bar and the S-hooks to the sling. In order to obtain the full 62 inch lifting range of the lifter, the chains must be used in full length. Patient's arms may rest outside of chains. When the patient is lifted so that he just clears the chair, the lifter boom should be almost at maximum height. Patient can then be lowered the full 62 inches. Follow lifting instructions in Lifter instruction manual.